

SPX **ROBINAIR**

Operating Manual

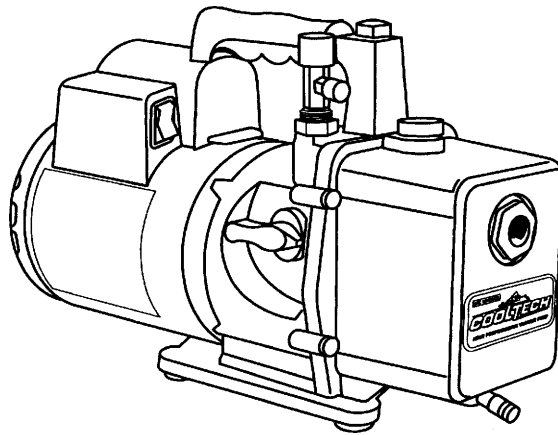

**High Performance Vacuum Pump
Models 15400 and 15600**

CoolTech® High Performance Vacuum Pumps

Congratulations on purchasing one of Robinair's top quality CoolTech® vacuum pumps. Your pump has been engineered specifically for air conditioning and refrigeration service, and is built with Robinair's proven offset rotary vane for fast, thorough evacuation. You'll appreciate these key features...

- Iso-Valve™** Allows the pump to be shut off while still connected to the A/C-R system, which is handy for checking rate of rise. With the valve handle in the "Open" position, the pump is open to the system being evacuated. In the "Closed" position, the pump is isolated from the system.
- High Vacuum Rating** The two-stage, offset rotary vane design provides powerful, quiet high vacuum capability and assures moisture removal, while the high pumping capacity reduces evacuation time.
- Lifetime Filtration** The intake filter prevents foreign matter from entering the pumping chamber, and an internal exhaust filter separates oil vapor from the exhaust flow.
- Directed Exhaust** The exhaust is expelled through the handle to direct it away from the service technician.
- Gas Ballast** A precise amount of atmospheric air is introduced into the pump, preventing condensation of moisture vapor and helping maintain the purity of the pump oil. By using the gas ballast, the pump operates more efficiently and pump life is extended.
- Sure-Grip Handle** The one-piece, molded handle makes it easy to carry the pump to and from job sites, and the handle stays cool to the touch during operation.
- Compact Design** Your pump measures just 15½" long, while aluminum housing and offset rotary vanes keep the pump weight low, making it easy to carry.

For use on A/C-R systems using CFCs, HCFCs, and HFCs in conjunction with mineral oil, ester oil, alkylbenzene oil, and PAG oil as lubricants. Not for use with ammonia or lithium bromide systems. Not for use with flammable refrigerants.

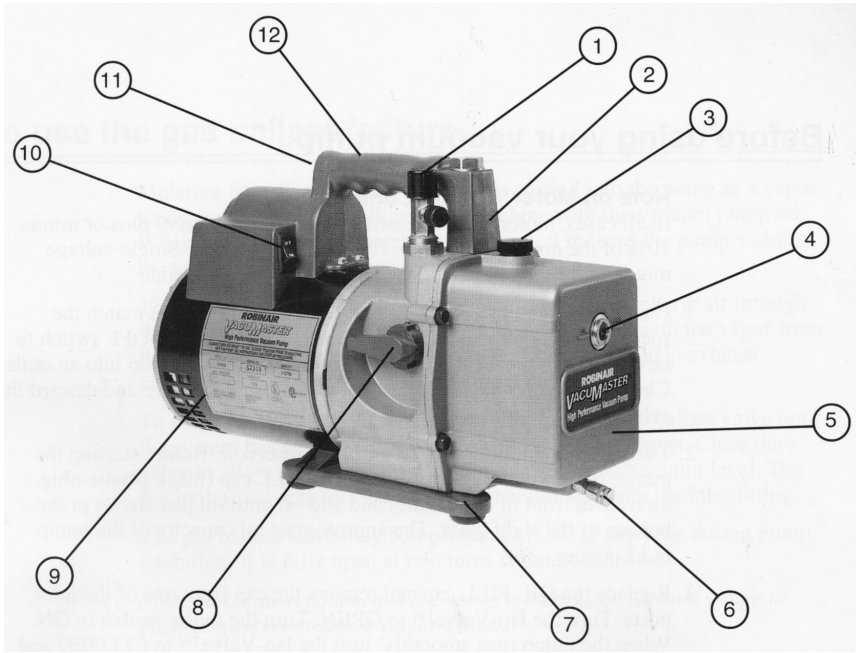

Pump Components

- | | |
|---|--|
| 1. Intake Fitting | 7. Molded Polycarbonate Base |
| 2. Gas Ballast Valve (located beside handle base) | 8. Iso-Valve™— Isolates the pump from the system |
| 3. Oil Fill Port | 9. Powerful, High Torque Motor |
| 4. Sight Glass | 10. Power Switch |
| 5. Die-Cast Aluminum Housing | 11. Through-The-Handle Exhaust |
| 6. Oil Drain | 12. Sure-Grip Handle |



WARNING!



When working with refrigerants, goggles should always be worn. Contact with refrigerants may cause injury.



Improper use or connections may cause electrical shock hazards. Read and follow the instructions carefully and take precautions to avoid electrical shock hazards. Be sure that all associated devices are properly grounded before energizing circuits.



The normal operating temperature will cause certain external portions of the pump to be hot to the touch. Do not touch the pump housing or motor during operation.

Before using your vacuum pump...

Note on Motor Voltage Connections:

In all cases, motors are designed for operating voltages plus or minus 10% of the normal rating (see SPECIFICATIONS). Single voltage motors are supplied fully connected and ready to operate.

1. Check to be sure the voltage and frequency at the outlet match the specifications on the pump motor decal. Check the ON-OFF switch to be sure it is in the OFF position before you plug the pump into an outlet. Check to be sure the gas ballast valve is closed. Remove and discard the exhaust plug from the end of the pump's handle.
2. The pump is shipped without oil in the reservoir. Before starting the pump, fill it with oil. Remove the OIL FILL cap (black plastic plug directly in front of the handle) and add oil until oil just shows in the bottom of the sight glass. The approximate oil capacity of the pump is 15 ounces.
3. Replace the OIL FILL cap and remove the cap from one of the inlet ports. Turn the Iso-Valve™ to OPEN. Turn the motor switch to ON. When the pump runs smoothly, turn the Iso-Valve™ to CLOSED and replace the cap on the inlet port. This may take from two to 30 seconds depending on the ambient temperature. After the pump runs for approximately one minute, check the sight glass for proper oil level — oil should be even with the sight glass OIL LEVEL line. Add oil if necessary.

Note: When the pump is running, the oil level should be even with the line on the sight glass. Underfilling will result in poor vacuum performance. Overfilling can result in oil blowing from the exhaust.

Your pump is now ready to evacuate air conditioning and refrigeration systems. Follow normal service procedures and the A/C-R manufacturer's instructions for connections to the system.

CAUTION! Before connecting your vacuum pump to an A/C-R system, remove refrigerant from the system in an accepted manner. Damage to the pump may occur if evacuation is started while the system is under high pressure. Robinair recommends use of our Refrigerant Recovery and Recycling equipment.

To use the gas ballast feature...

Moisture from the A/C-R system that is carried into the pump as a vapor tends to condense into a liquid and combine with the vacuum pump oil. When moisture contaminates the pump oil, it reduces the pump's ability to reach its ultimate deep vacuum level.

The gas ballast valve purges a small amount of atmospheric air through the exhaust chamber. This extra volume of air mixes with the vapor from the refrigerant system to prevent condensation and to help exhaust moisture in the form of vapor from the pump.

To use the gas ballast, start the pump and open the gas ballast valve until the system has reached approximately 1000–3000 microns. Close the valve to allow the pump to pull down to its ultimate vacuum level. The gas ballast valve is located beside the handle, opposite the inlet fitting.

The gas ballast valve may be opened or closed at any time during pump operation. It is fully open at two turns counterclockwise.

Note: Robinair recommends the use of a thermistor vacuum gauge to most accurately measure vacuum levels.

To shut down your pump after use...

To help prolong pump life and promote easy starting, follow these procedures for shutdown:

1. Close the manifold valve between the pump and the system.
2. Turn the Iso-Valve™ to the CLOSED position.
3. Remove the hose from the pump inlet.
4. Turn the pump power switch to OFF, then return the Iso-Valve™ to the OPEN position for a few seconds to relieve any vacuum inside the pump.
5. Cap the inlet port to prevent any contamination or loose particles from entering the port.

To maintain your high vacuum pump...

Vacuum Pump Oil

For maximum performance, Robinair recommends changing vacuum pump oil after each use.

The condition and type of oil used in any high vacuum pump are extremely important in determining the ultimate attainable vacuum. Robinair recommends the use of our Premium High Vacuum Pump Oil. This oil has been specifically blended to maintain maximum viscosity at normal running temperatures and to improve cold weather starts.

Robinair Premium High Vacuum Pump Oil is available in handy quart containers or in convenient gallon containers. Order by part number:

13203 — Quart (shipped 12 quarts per case)

13204 — Gallon (shipped 4 gallons per case)

Oil Change Procedure

1. Be sure the pump is warmed up.
2. Remove the OIL DRAIN cap. Drain contaminated oil into a suitable container and dispose of properly. Oil can be forced from the pump by opening the inlet and partially blocking the exhaust with a cloth while the pump is running. Do not operate the pump for more than 20 seconds using this method.
3. When the flow of oil has stopped, tilt the pump forward to drain residual oil.
4. Replace the OIL DRAIN cap. Remove the OIL FILL cap and fill the reservoir with new vacuum pump oil until the oil just shows at the bottom of the sight glass. The approximate oil capacity of the pump is 15 ounces.
5. Verify the inlet ports are capped, then turn ON the pump. Allow it to run for one minute, then check the oil level. If the oil is below the sight glass OIL LEVEL line, add oil slowly (with the pump running) until the oil reaches the OIL LEVEL line. Replace the OIL FILL cap, making sure the inlet is capped and the drain cap is tight.
6. a) If the oil is badly contaminated with sludge that forms when water is allowed to collect in the oil, you may need to remove the oil reservoir cover and wipe it out.

- b) Another method of dealing with heavily contaminated oil is to force the oil from the pump reservoir. To do this, allow the pump to run until it is warmed up. While the pump is still running, remove the oil drain cap. Slightly restrict the exhaust. This will back-pressure the oil reservoir and force the oil from it, carrying more contaminants. When the oil ceases to flow, turn off the pump.

Repeat this procedure as required until the contamination is removed. Replace the OIL DRAIN cap and refill the reservoir to the proper level with fresh pump oil (see Step 4).

Cleaning the Pump

Clean the pump with soap and water only. Do not use commercial cleaners that contain degreasing agents that can damage polycarbonates. The pump handle and base are made of Lexan[®], one of the toughest polycarbonate plastics available. However, it is sensitive to degreasing agents.

**Lexan is a registered trademark of General Electric.*

Troubleshooting Guide

Your CoolTech[®] pump has been designed for dependable use and long life. If something should go wrong, however, the following guide will help you get the pump back into service as quickly as possible.

If disassembly of the pump is required, please check your warranty. The warranty may be voided by misuse or customer tampering which results in the pump being inoperable.

Failure To Start

Check the line voltage. Robinair pumps are designed to start at $\pm 10\%$ line voltage (loaded) at 32° F. At extremes, however, switching between the start and run windings may occur.

Oil Leakage

1. Be sure the oil is not a residual accumulation from spillage, etc.
2. If leakage exists, the module cover gasket or the shaft seal may need replacing. Follow the instructions supplied with the Seal Replacement Kit, part number 15367. If leakage exists in the area of the oil drain plug, you may need to reseal the plug using a commercial pipe thread sealer.

Failure To Pull A Good Vacuum

1. Be sure the Iso-Valve[™] on the pump is in the OPEN position.
2. Be sure the vacuum gauge and all connections are in good condition and leak-free. You can confirm leakage by monitoring the vacuum with a

thermistor gauge while applying vacuum pump oil at connections or suspected leak points. The vacuum will improve briefly while the oil is sealing the leak.

3. Be sure the pump oil is clean. A badly contaminated pump may require several oil flushes. See OIL CHANGE PROCEDURE.

Note: Use only high vacuum pump oil such as Robinair's Premium High Vacuum Pump Oil. Other oils will prevent pull-down to a deep vacuum.

4. Check to be sure the gas ballast knob is tightly closed.
5. Be sure the oil is at the proper level. For maximum pump operation, the oil must be even with the OIL LEVEL line on the sight glass when the pump is running. See OIL CHANGE PROCEDURE. Do not overfill — operating temperatures will cause the oil to expand so it will appear at a higher level than when the pump is not running. To check the oil level, start the pump with the inlet capped. Check the oil level in the sight glass. Add oil if necessary.

When You Need Help

If these procedures do not correct the problem, contact your nearest Robinair distributor. The distributor may recommend an additional replacement part (this manual contains a parts list) or suggest you send your pump to the nearest authorized service center. Call Robinair's toll-free Service Line for further information:



Warranty Coverage

Robinair CoolTech[®] vacuum pumps are warranted against defects in material and workmanship for one year of normal use from the date of purchase. See your distributor for warranty details.

Out of Warranty

A pump which is no longer covered by the one-year warranty period and which fails to operate properly should be returned to the distributor with a full written explanation of the problem, or you may return it yourself to one of the authorized Robinair Service Centers for repair.

Prior to returning an out-of-warranty pump, review all maintenance procedures to avoid an unnecessary return. Note that contaminated oil or an incorrect oil level will adversely affect pump performance. Replacement parts are available for doing your own service. However, this should be considered only in out-of-warranty situations.

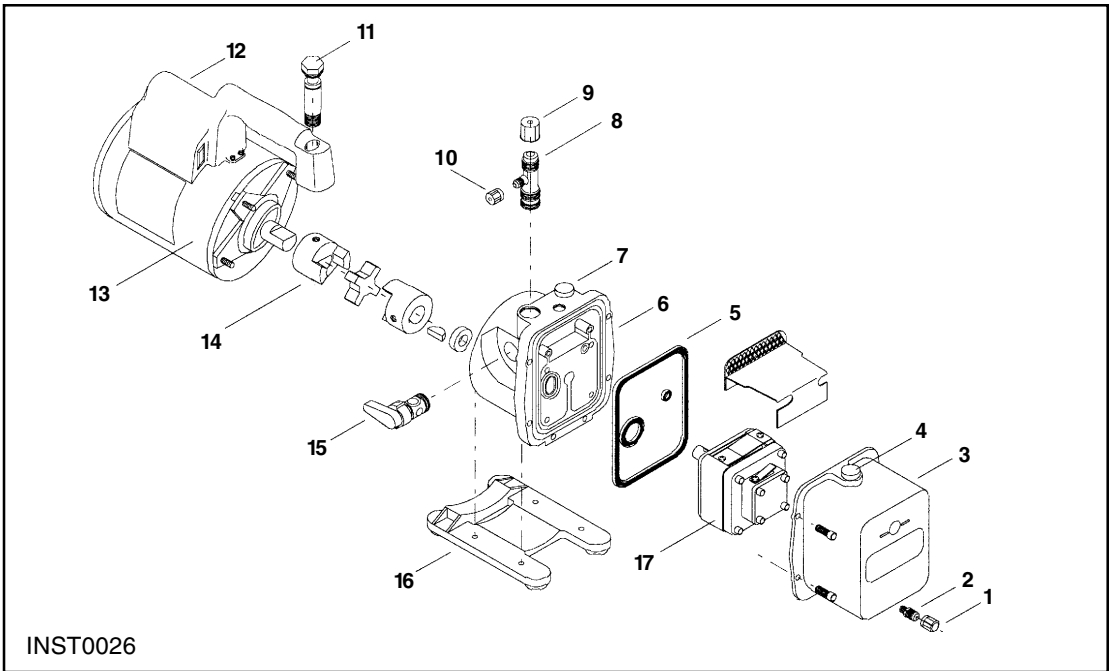

Replacement Parts

Part	Figure	15400	15600
Oil Drain Cap (6)	1	40572	40572
Oil Drain Kit (includes #1)	2	48116	48116
Module Cover Kit (includes #2, #4 and #5)	3	15337	15337
Oil Fill Cap (includes #7)	4	15371	15371
Intake Fitting (includes #9 and #10)	8	15364	15364
Intake Cap (2), 1/2" flare	9	41135	41135
Intake Cap (6), 1/4" flare	10	41139	41139
Vent Bolt (includes O-rings)	11	15338	15338
Handle, Power Cord and Switch Assembly	12	15366	15366
Motor	13	15365	15370
Coupling	14	48103	48103
Iso-Valve™ Assembly	15	15368	15368
Base and Foot Assembly	16	15369	15369
Replacement Module (includes #1 through #7)	17	15547	15548
Seal Replacement Kit (not shown)	--	15367	15367

VacuMaster Pump Specifications

Model	15400	15600
Free Air Displacement	4 CFM	6 CFM
Stages	2	2
Motor Speed	1725 RPM	1725 RPM
Voltage $\pm 10\%$	115V 60 HZ	115V 60 HZ
Factory Micron Rating	20 microns	20 microns
Approximate Oil Capacity	15 oz.	15 oz.
Weight	29 lbs.	29 lbs.
Width	5 ⁵ / ₈ in.	5 ⁵ / ₈ in.
Height	9 ³ / ₄ in.	9 ³ / ₄ in.
Length	15 ¹ / ₂ in.	15 ¹ / ₂ in.
Intake	1/2" and 1/4" SAE MFL	1/2" and 1/4" SAE MFL
Min. Starting Temp. (at 90% Voltage)	32°F	32°F
Motor Size	1/3 hp Capacitor Start	1/2 hp Capacitor Start
Operating Temp.	155°F	155°F

- Note:*
1. All motors are internally protected (automatic reset).
 2. Operating temperatures are typical for normal operating conditions.

U.S. Patents: 4,523,897; 5,209,653. Other U.S. and Foreign Patents Pending.

Due to ongoing product improvements, we reserve the right to change design, specifications and materials without notice.



*SPX Corporation
655 Eisenhower Drive
Owatonna, MN 55060-0995 USA
Technical Services: 1-800-822-5561
Fax: 1-800-822-7805
Customer Service: 1-800-533-6127
Fax: 1-800-322-2890
Web Site: www.robinair.com*

IMPORTANT

Warranty Registration Card

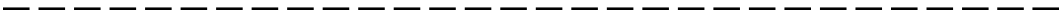

PLACE
FIRST
CLASS
POSTAGE
HERE



ROBINAIR

SPX Corporation
655 Eisenhower Drive
Owatonna, MN 55060-0995





High Performance Vacuum Pump

WARRANTY REGISTRATION CARD

IMPORTANT: Complete this card and return it within 10 days from date of purchase in order to validate the warranty. See your distributor for complete warranty details.

Model No. _____ Serial No. _____ Date of Purchase _____

Purchaser's Name _____

Business Name _____ Telephone: _____

Address _____

City _____ State _____ Zip Code _____

Purchased From _____

Address _____

City _____ State _____ Zip Code _____

FOLD ON THIS LINE, TAPE TO SEAL AND PLACE POSTAGE ON OUTSIDE

Questionnaire

We would appreciate your answers to these questions. They will assist us in meeting your future product and service needs. Thank you.

1. What type of service work do you perform?

____% Automotive ____% Residential
____% Commercial A/C ____% Refrigeration

2. What influenced your decision to buy Robinair?

- Advertising
- Literature/Brochure
- Distributor Display/Promotion
- Friend's Recommendation
- Distributor's Recommendation
- Previous Satisfaction with Robinair Product(s)
- Robinair Reputation Warranty Coverage
- Product Availability After-Sale Service
- Other (please explain) _____

3. If this is a replacement pump, what brand does it replace? _____

4. Do you own any other Robinair equipment?

Yes No

If yes, please check the Robinair items you own:

- Refrigerant Recovery/Recycling Equipment
- Manifold Gauge Set Tubing Tools
- Dial-A-Charge® Charging Hoses
- Fittings and Valves Test Equipment
- Thermistor Leak Detector
- Vacuum Gauge
- Other (explain) _____

5. Do you currently own refrigerant recovery and recycling equipment? Yes No

If no, are you considering buying this type of equipment in the future? Yes No